

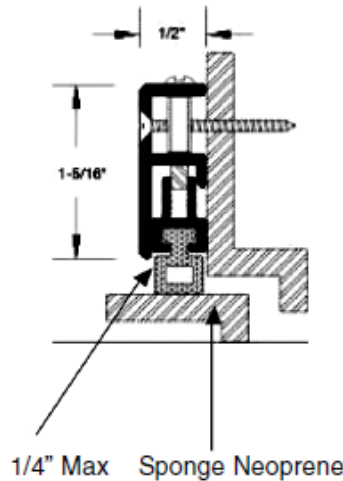

Box 459 - Rosemount, MN 55068  
 Phone 800-328-0953  
 Fax 800-334-8823



### Adjustable Door Stop Part # 33 & 633

Please Note: Where Door Stop is to be applied is on top of existing stops, it is recommended that locks with a 3-3/4" back set be used rather than locks with a 2-3/4" back set. This allows adequate space between the door knob and the Door Stop.

1. When the Door Stop is shipped from the factory, the gasketing is screwed completely into the housing. All adjusting screws should be screwed so that the face of the insert projects out of the housing approximately 3/16". This will then allow for subsequent adjustment in either direction.

2. The insert gasket should be longer than the aluminum retainer. As supplied from the factory, pieces are approximately 1/4" oversize. This is the correct amount of extra gasket to squeeze toward the center of the strip during installation to produce a tight joint at mitered corners without the necessity of using an adhesive.

3. When trimming the Door Stop to exact length for installation, make certain that an extra 1/2" of gasket extends beyond the opposite end before making the cut.

4. Close the door and place hinge side assembly against the face of the door making gentle contact over full height. Fasten in place.

5. With the door still closed, place the lock side assembly against the face of the door making gentle contact over full height. Fasten in place.

6. With the door still closed, place the head assembly against the face of the door making gentle contact over full width. Fasten in place.

7. Operate the door several times to ensure the gasketing material is properly adjusted so it does not inhibit the self closing and latching of the doors.



Positive Pressure Tested Gasketing Materials for Fire Doors. Intended for Application to/ with listed steel frames and/or classified steel covered composite, hollow metal type fire doors rated up to 3 hours, wood and plastic covered composite type fire doors rated up to 1-1/2 hours, and wood core type fire doors rated up to 20 minutes.

Meets UL10B, UL10C  
 Category J, Category H.  
 Meets CAN4-S104-2010  
 Can use on 'S' Labeled doors.  
 17L5

